

Essay: Bamboo Skyscraper

Arch 346 Competition Elective

Instructor: Terri Boake

Author: Di Wang

Bamboo Skyscraper was designed for the 2013 Super-Skyscraper Competition, which asked for an inspirational, high quality Architect's Vertical Village Bamboo Skyscraper concept in Singapore¹. Our proposal, a 500m skyscraper containing programs of working, living, studying and entertaining, reflects the concept of vertical village and suggests a structural system based on hyperboloid structural tubes made of bamboo culms. I will discuss how the research on precedents and relative topics shaped the design of Bamboo Skyscraper in this essay.

Vertical Village

Contemporary skyscrapers are often criticized as blind competitions of height. According to the research conducted by CTBUH², in the 65 years between 1930 and 1995, only 15 'Supertalls' (Above 300m) were completed. In the mid 1990s there were more than one 'Supertall' to be added to the lists annually. Nowadays, less than two decades later, the number of 'Supertalls' completed annually is double digits. Meanwhile, the number of 'Megatalls' (Above 600m) set to complete in the next decade is similar to the number of 'Supertalls' completed in the 90s^{3 4}.

At the same time, less and less design attention is put on the variety of space and programs. As concluded by scholars, skyscrapers today have quite deliberately separated the formalistic and the functionalist⁵. It has been seen as a typology with vacuous nature, loss of program, and refuse the futile competition for height⁶.

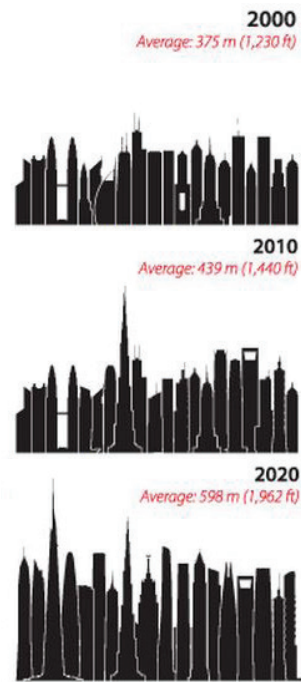

Figures 3: The change of World Top 20 Skyscraper in two decades.

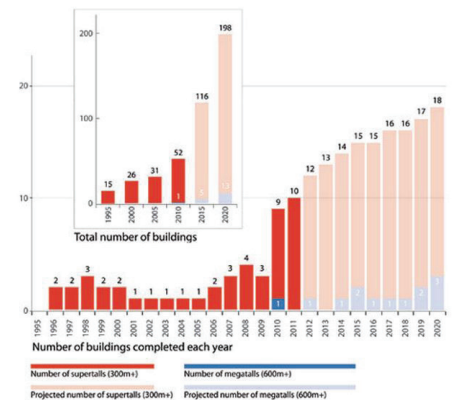

Figure 7: Supertall and megatall building completion showing a significant projected increase. © CTBUH
Note: CTBUH can accurately predict the number of supertall completion through 2013. The figures for following years are estimates based on current building trends and construction activity.

Figures 4: The completion numbers of 'Supertalls' and 'Megatalls' from 1995 to 2020.

1. SSS Bamboo Skyscraper Singapore Brief. London: Super Skyscraper Competition, 2013. Print.
2. Council on Tall Buildings and Urban Habitat. "The Tallest 20 in 2020: Entering the Era of the Megatall." (2011): n. pag. Web.
5. Muijnck, Bert De. "The End of the Skyscraper as We Know It: From CCG to CCTV." *Movingcities.org*. Archis#5, May 2004. Web. Dec. 2015.
6. Koolhaas, Rem. *Content*. Cologne (Taschen) 2004, p. 44.

The concept of vertical village opposes itself to the trend of contemporary skyscraper. A vertical village is a dense vertical structure that offers a variety of programs to sustain everyday life. The earliest model of vertical village is Unité d'habitation by Le Corbusier. The single-slab 'vertical village' is equipped with an internal shopping street, a recreation ground and children's' nursery on the roof, and a generous surrounding area of park land.

In Rem Koolhaas's book *Delirious New York*, Koolhaas gives us another example of vertical village, the Downtown Athletic Club⁷ in New York. Looking at its section⁷, there is a variety of scales and spatial typologies, supporting the its fantastic juxtaposition of activities⁸. The Downtown Athletic Club creates a new urban territory and becomes an incubator of new type of metropolitan life style.

In his research titled *Vertical Village Taipei*⁹, Winy Maas looked at the very intimate scale and grain of an old urban district in Taipei, and proposed a three-dimensional community, a cluster of stacked buildings with diverse geometries, colors and textures. The Peruri 88, designed by MVRDV, is the physical manifestation of his research. During the design we looked at the potential of a normally homogeneous skyscraper being segregated into smaller masses. Not only does the segregation create a diversity on the facade and massing, but also increases the area of sky gardens, which is very welcoming in South-east Asia.

PinkCloud.dk's *Shanghai Flip/City*¹⁰ proposed a slab structure that literally reflects the plan of the Shanghai urban fabric. The proposal flips the horizontal cityscape into vertical. In this case we looked at how the 'flipping' concept allows the design to preserves the human scale and community diversity, and provides a flexible framework with the capacity to maximize green space¹¹.

The contemporary architecture in Singapore demonstrates a strong appreciation of the concept. Among which the most iconic building based on the concept is the Marina Bay Sands¹³, which houses a hotel, convention and exhibition facilities, theatres, entertainment venues, retailers and restaurants. The building lifts up a 2.5-acre land called the Skypark, which is equipped with restaurants, gardens, and a 150-metre vanishing edge pool. Since Marina Bay Sands, the design

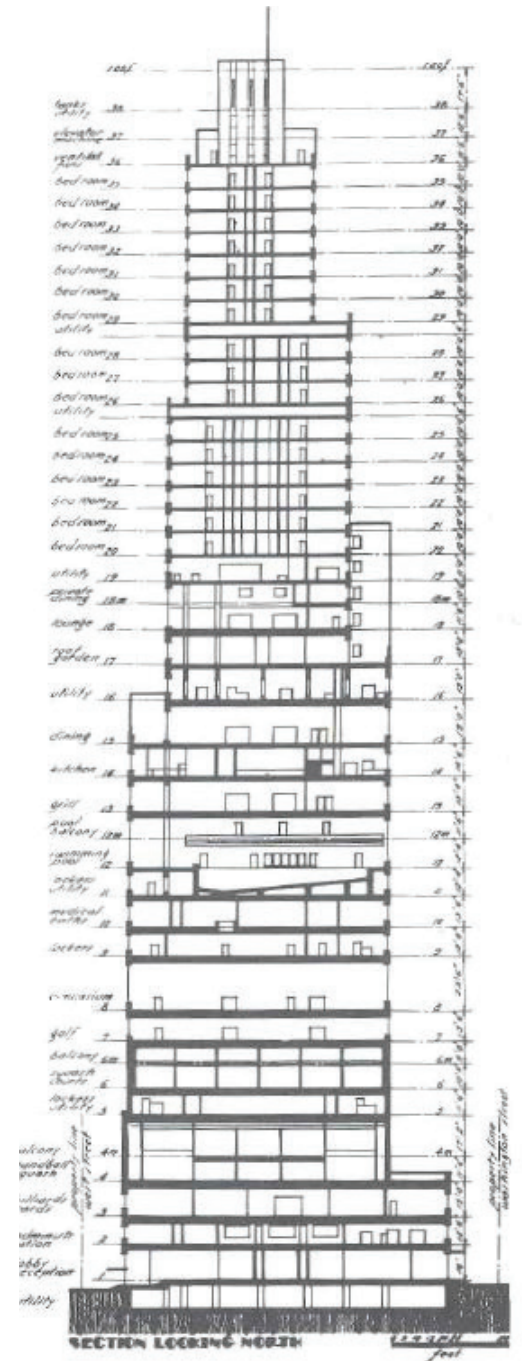

Figure 7: Section of Downtown Athletic Club



Figure 8: Vertical Village Taipei Exhibition

8. Koolhaas, Rem. *Delirious New York: A Retroactive Manifesto for Manhattan*. New York: Monacelli, 1994. Print.

11. PinkCloud.dk. "Flip/City Shanghai." »PINKCLOUD.DK. N.p., 2012. Web. 22 Dec. 2014.

of hotels and condominiums in Singapore often incorporates “sky gardens” “sky decks” and “sky lounges”. It shows the strong appreciation of the concept of vertical village, which we considered in our proposal as the preference of Singaporeans.

Referring to the concept from Shanghai Flip/City, we took a piece of surrounding urban fabric and flipped it to vertical position, as the diagram¹³ has shown. It allows a direct functional translation of the horizontal urban fabric in vertical dimension, and thus allows a certain degree of familiarity to the new vertical urban fabric. Different zones are translated into strata of programs¹⁴: hotel, condominium, shopping center, restaurant, office, school and museum. Streets are translated into spacious structural tubes containing elevators and stairs to create vertical promenades. To use these tubes as means of circulation more effectively, each is designated to the users of specific program. On the ground level, 12 tubes forms a portal space¹⁵ open to the adjacent wood lawn on the site. Public parks and empty lots are translated into sky lounges¹⁶ in office section or community spaces in condominium section.

Referring to the section of Downtown Athletic Club, we introduced a variety of spatial typologies to give each program a unique experience. For example, the shopping center is unique for its terraced slabs which give a strong orientation towards the sea view. The school is featured with sloped slab used as lecture seatings. The various spatial experiences contribute to the diversity of vertical village.

Referring to the massing segregation of Peruri 88, we spatially separated programs apart with in-between sky gardens for outdoor activities, echoing with the skyscraper typology in Singapore. The underside of each program mass is also terraced to allow sufficient natural sunlight. The division of the skyscraper with sky gardens visually creates an impression as a village with multiple organizations.

In this vertical village, residents, workers, students and customers gather under the bamboo canopies, creating a lively scenes consisting of many professions. An individual living inside the skyscraper can possess multiple identities. The life in vertical village is full of choices and interactions.



Figure 9: Peruri 88

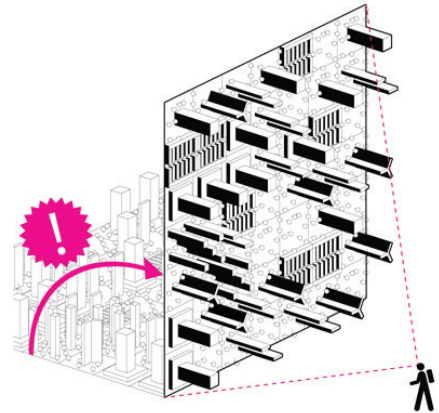

Figure 10: Shanghai Flip/City



Figure 12: Marina Bay Sands

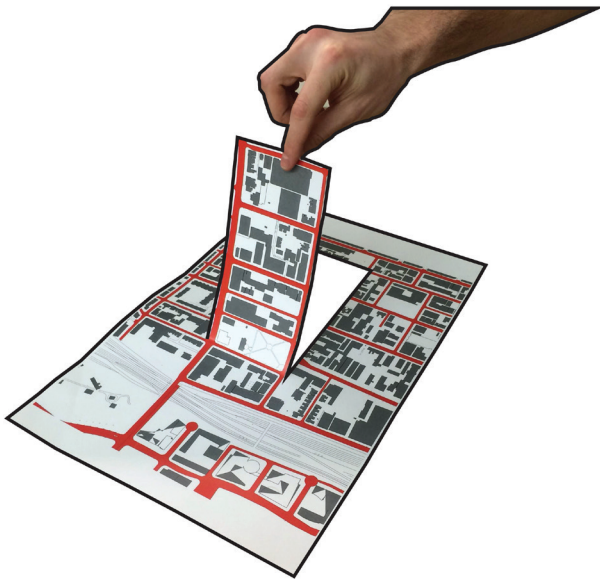

Figure 13: Parti diagram



Figure 15: Portal space



Figure 16: Sky-lounge

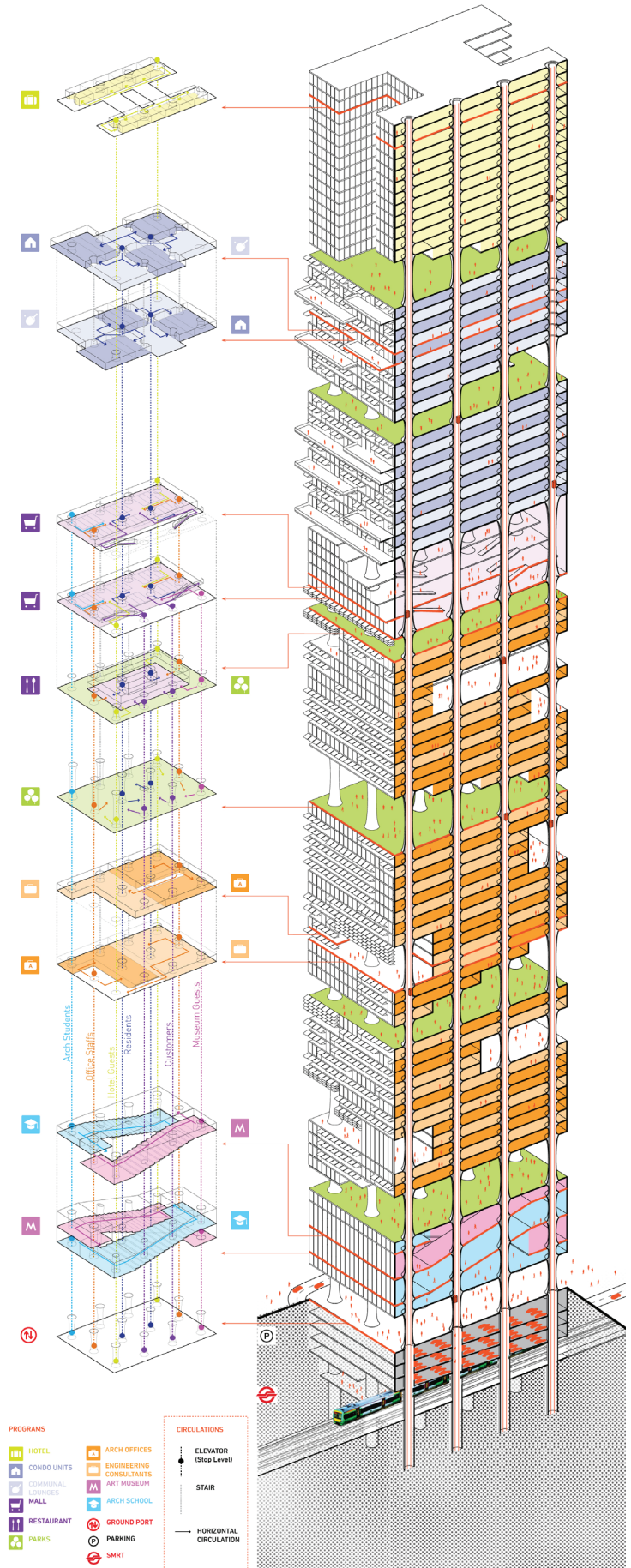

Figure 14: Section of the proposal

Bamboo

The competition guideline specifies the skyscraper to be constructed with bamboo. In our proposal, bamboo is highly valued by its material properties, sustainability and aestheticism.

Bamboos are the fastest growing plants in the world. Bamboo forest plantations reach maturity in 4-6 years and culms can be harvested 2-3 years later¹⁸. The special interconnected root system, the rhizome mat, sends up new shoots after individual bamboo is harvested. Thus, it can be harvested without replanting. In our calculation the amount of bamboo culms we use in constructing Bamboo Skyscraper only take 2 years to grow in a typical 1,000 hectare plantation.

Bamboo is a material with high strength and low weight, and is easily worked using simple tools. Research conducted by ICBR reveals that the average tensile modulus and strength of bamboo fibers are both significantly higher than wood fibers¹⁹. Bamboo constructions are easy to build, resilient to wind and even earthquake forces and readily repairable²⁰. In practical field, Bamboo scaffolds²¹ remain to be one of the most preferred systems for access, due to its high strength-to-weight ratio, simple erection, and easy adaptability to building forms and site conditions²². In China, bamboo is also adopted in the construction of simple suspension bridges.

It is very convenient to prefabricate bamboo structures and assemble on site. Bamboo culms can be harvested and fabricated into structural members in local regions and easily shipped to other locations. In today's bamboo housing market, the assembly time for an entire bamboo dwelling can be as short as two days^{23 24}.

Bamboo's structural merits are interpreted into cultural iconographies. It represents the qualities of durability, strength, flexibility and resilience since it will bend in severe weather



Figure 17: A worker is harvesting bamboo culms in a bamboo plantation.



Figure 21: Bamboo scaffolding



Figure 24: Prefabricated bamboo homes



Figure 26: Bamboo in Chinese painting

17. "Bamboo vs Trees." N.p., n.d. Web. 27 Dec. 2014. <<http://www.bamboolive.com/index.php/why-bamboo/bamboo-vs-trees>>.

18. Yu, Yan, Ge Wang, and Benhua Fei. Are Bamboo Fibers Stronger and Stiffer than Wood Fibers ? Thesis. 2012. N.p.: International Center for Bamboo and Rattan (ICBR), n.d. Print.

19. INBAR Technical Report No.16. N.p.: n.p., n.d. 5. Print.

22. Chung, K F, and S L Chan. Design of Bamboo Scaffolds. N.p.: n.p., 2002. 9. Print.

23. Joyce. "Prefabricated Bamboo Homes." Shoo-foo. N.p., 2010. Web. 22 Dec. 2014.

25. China: Journey to the East. N.p.: British Museum, 2008. Print.

without breaking itself²⁵. In history, Its image and motif was frequently depicted in Chinese paintings. In Singapore culture which has deep connection to that of China, the reason of building a bamboo structure is beyond the utilitarian value. It is a construction of long-appreciated cultural iconography.

When using bamboo culms as structures, bamboo is notorious for splitting easily along its length. However, one species of bamboo that is well known in Latin America, Guadua Bamboo, is highly resistant to splitting and has excellent nail holding properties²⁷, which makes it an excellent species in construction. Thus, Guadua Bamboo is the chosen species for Bamboo Skyscraper.

Structural System

A critical part of our design is to develop a structural system that could be compatible with bamboo. Three precedents were used as primary references.

The first precedent is Kontum Indochine Café²⁸ designed by Vo Trong Nghai Architects. The building is supported by 15 inverse-cone-shaped columns using bent bamboo culms. The bent bamboo culms are bundled together with ropes, adding to the strength of the columns. The cone shape capitals of the columns shorten considerably the structural span of the bamboo roof structure. Visually, it resembles the form of bamboo forest, which gives the space a pleasant natural feeling.

The second precedent is the German-Chinese House²⁹ designed by Markus Heinsdorff and MUDI. Metal connections and finishing techniques were developed for this project. Connecting joints of steel on the roof hold together the bamboo supporting frame structure. The bamboo was treated with a fire-resistant chemical. On the building's facade, the bamboo serves as the structure for ETFE facade.

The third precedent is Sendai Mediatheque³⁰ designed by Toyo Ito Architects. A unique type of structure is introduced: structural tubes composed of thick-walled steel pipes that function similarly as columns. The exposed structures of the tubes are connected to the embedded structure within the slabs, forming an interconnected steel web from vertical to horizontal plane³¹. The thirteen irregularly shaped structural tubes of the mediatheque house all of the buildings systems including HVAC, electric, network cables, stairs, and elevators. The structural tubes provide the necessary seismic



Figure 28: Kontum Indochine Café



Figure 29: German-Chinese House, Expo 2010

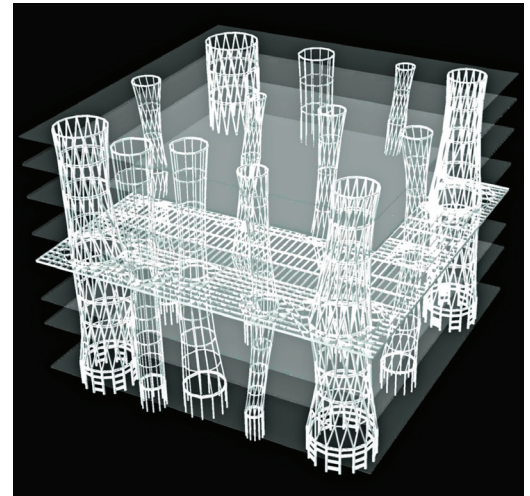

Figure 30: Tubular structure of Sendai Mediatheque.

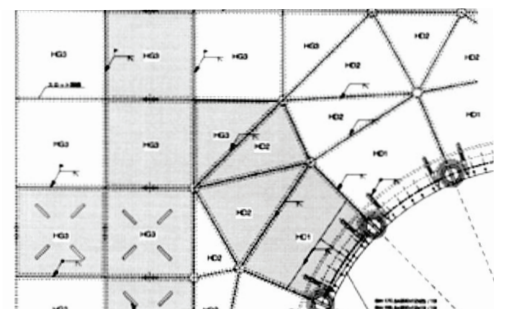

Figure 31: Connection between slab structure and structural tube.

27. Ghosh, G. K. Bamboo: The Wonderful Grass. New Delhi: A.P.H. Pub., 2008. 90. Print.

bracing to the building.

From Kontum Indochine Café, we know by bundling up bamboo culms we can create an effective bamboo column structure. From German-Chinese House we realize the industrialization and standardization of bamboo construction in terms of material selection and detailing. With the knowledge in mind, based on the tubular structure developed in Sendai Mediatheque, we designed a bamboo web structural system. 12 Hyperboloid^{32 33} structural tubes that are 5m in diameter are proposed in the design. The hyperboloid has a unique property: its surface can be entirely covered by two families of straight lines. The strength of the structure lies in the intersections between two families of straight elements which acts as cross bracing.

Vigilante Maule by Carlos Jarpa was a hyperboloid timber frame tower built with treated 2x2" pine slats joined together by a system of modular metal plates^{34 35}. This hyperboloid structure manages to transfer the heavy loads evenly throughout the volume. The Timber Frame Tower implies that two layers of straight bamboo culms can be braced with each other to form a hyperboloid structural unity. The connections at the intersections between the two layers are designed to be Herbert shear pin connector^{36 37} which allows connection happens between bamboos in multiple directions. The strength of the hyperboloid tubes can be further enhanced by adding more layers of bamboo culms to achieve adequate wall thickness for load bearing, especially at lower section of the skyscraper where axial load accumulates.

To further design the system, we looked at bamboo's bendability. Unlike bending timber which requires steam bending, a freshly cut bamboo culm can be bent locally using localized application of heat. In this process, heating softens the resin of the composite permitting the fibers to move in relation to each other to achieve a sharp bend³⁸. With this knowledge in mind, we designed the two layers of bamboo culms in a way that only the outer layer of bamboo culms are locally bent near trisection points to form horizontal sections for constructing slabs. For example, the bamboo slabs inside a rectangular area defined by four hyperboloid tubes at corners will be constructed with four layers of culms that branch out from the four tubes, which forms a floor assembly of 400mm deep

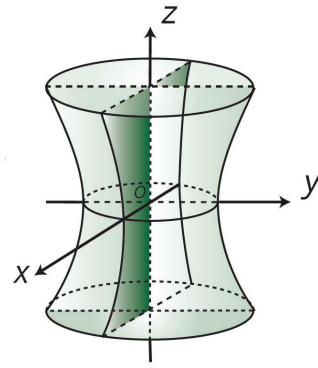

Figure 32: Hyperboloid one sheet

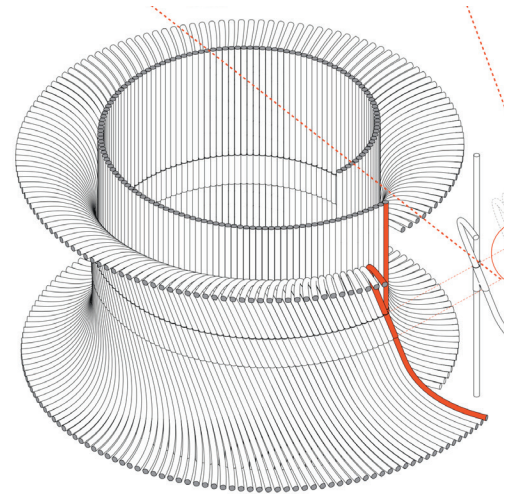

Figure 33: Bamboo Skyscraper hyperboloid column diagram



Figure 34: Vigilante Maule

34. "Carlos Jarpa's Vigilante Maule Is a Timber Frame Tower Looking Out Over Chile's Vineyards." Inhabitat. N.p., n.d. Web. 27 Dec. 2014.

36. INBAR Technical Report No.16. N.p.: n.p., n.d. 76. Print.

38. Ghosh, G. K. Bamboo: The Wonderful Grass. New Delhi: A.P.H. Pub., 2008. 96. Print.

with bamboo web (Each layer of bamboo culms is designed to be around 100mm). To form continuous tubular structures through the whole height of the building, the inner layer of the hyperboloid tube is kept vertically straight to join with the inner layers of the tubes above and below. To extend the length of the bamboo, a method called butt joint with side plates is adopted³⁹. In this type of connection, culms of similar diameter are laid end to end. Side plates, made from quarter-round culms of slightly larger diameter and two or more internodes long, are fixed over the joint by tying and, usually, dowelling⁴⁰.

The continuation of hyperboloid tubes throughout the whole building, and of the bamboo culms from floor to ceiling results in a homogeneous structural system without distinguished tectonics. The system is a web of bamboo that is able to endure destructive natural forces. The tubular system in The Sendai Mediatheque was tested in the 2011 Great East Japan Earthquake (9.0 Mw), with little damage on its structure⁴¹. At the same time, Singapore is exposed to the dangers of earthquakes and typhoons, due to its geographical location and maritime exposure. Thus we believe such a three dimensional web-like structure, with its fibers in structural tubes fan out to interweave with the fibers from other tubes, would have considerable resistance over disasters.

Durability of natural material is also taken into consideration. Without treatment, bamboo is prone to deteriorate due to the attack of fungus and insect. It is practical to use dye, chemicals and smoking finishes and chemical treatment to decorate and ward off insect, fungus and borer attack⁴². The process of fire retardant treatment is normally carried out by pressure treatment. The short come of the treatment is the high cost. An alternative is water mist system. Since normal sprinkler system will cause issue on bamboo surface, a water mist system is adopted in the design. It has limited water damage to the object⁴³. Water mist refers to fine water sprays in drops within 1000 microns in diameter. It has limited or no water damage on the bamboo structure.

Summary

Throughout the design process of Bamboo Skyscraper, we

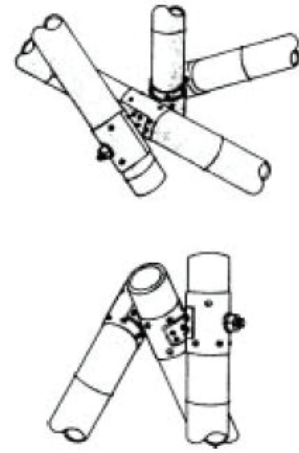

Figure 37: Herbert shear pin connector

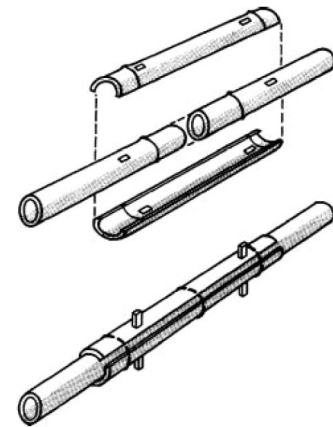

Figure 39: butt joint with side plates

40. INBAR Technical Report No.16. N.p.: n.p., n.d. 65. Print.

41. "Why One Remained Standing." WSJ. N.p., 2011. Web. 23 Dec. 2014.

42. Ghosh, G. K. Bamboo: The Wonderful Grass. New Delhi: A.P.H. Pub., 2008. 99. Print.

43. Liu, Zhigang, and Andrew K. Kim. A Review of Water Mist Fire Suppression System - Fundamental Studies. Thesis. Institute for Research in Construction, n.d. N.p.: n.p., n.d. Print.

have researched on relative topics and precedents to help us develop concept, structural system and tectonic. First, by studying on the Downtown Athletic Club, Peruri 88 and Shanghai Flip/City, we developed the concept of vertical village in the project. Second, by researching on the properties of bamboo, and learning from Kontum Indochine Café, German-Chinese House and Sendai Mediatheque, we proposed a bamboo web structural system. Third, by studying the hyperboloid geometry, the timber construction Vigilante Maule Tower and bamboo detailing conventions form from other sources, we developed the tectonic and detailing for our proposal. We hope the Bamboo Skyscraper will evoke designers' interest in bamboo by showing bamboo's advantages as a strong, fast-growing and sustainable material and the possibilities of its application in high-rise building construction ■

Bibliography

"Bamboo vs Trees." N.p., n.d. Web. 27 Dec. 2014. <<http://www.bamboolive.com/index.php/why-bamboo/bamboo-vs-trees>>.

China: Journey to the East. N.p.: British Museum, 2008. Print.

Council on Tall Buildings and Urban Habitat. "The Tallest 20 in 2020: Entering the Era of the Megatall." (2011): n. pag. Web.

Chung, K F, and S L Chan. Design of Bamboo Scaffolds. N.p.: n.p., 2002. Print.

Ghosh, G. K. Bamboo: The Wonderful Grass. New Delhi: A.P.H. Pub., 2008. Print.

INBAR Technical Report No.16. N.p.: n.p., n.d. Print.

Joyce. "Prefabricated Bamboo Homes." Shoo-foo. N.p., 2010. Web. 22 Dec. 2014.

Koolhaas, Rem. Content. Cologne (Taschen) 2004.

Koolhaas, Rem. Delirious New York: A Retroactive Manifesto for Manhattan. New York: Monacelli, 1994. Print.

Liu, Zhigang, and Andrew K. Kim. A Review of Water Mist Fire Suppression System - Fundamental Studies. Thesis. Institute for Research in Construction, n.d. N.p.: n.p., n.d. Print.

Mediateque: Blurring Architecture, Blurring Boundaries. N.p.: n.p., n.d. Web. <sites.harvard.edu/fs/docs/icb.topic502069.files/mediateque.pdf>.

Muyncck, Bert De. "The End of the Skyscraper as We Know It: From CCG to CCTV." Movingcities.org. Archis#5, May 2004. Web. Dec. 2015.

MVRDV. "Vertical Village Taipei." Projects_MVRDV. MVRDV, 2011. Web. Dec. 2015.

PinkCloud.dk. "Flip/City Shanghai." »PINKCLOUD.DK. N.p., 2012. Web. 22 Dec. 2014.

SSS Bamboo Skyscraper Singapore Brief. London: Super Skyscraper Competition, 2013. Print.

Swienciki, Lawrence W. Hyperboloid Model. N.p.: n.p., 2012. Print.

"Why One Remained Standing." WSJ. N.p., 2011. Web. 23 Dec. 2014.

Yu, Yan, Ge Wang, and Benhua Fei. Are Bamboo Fibers Stronger and Stiffer than Wood Fibers ? Thesis. 2012. N.p.: International Center for Bamboo and Rattan (ICBR), n.d. Print.

Figure 3,4: Council on Tall Buildings and Urban Habitat. "The Tallest 20 in 2020: Entering the Era of the Megatall." (2011): n. pag. Web.

Figure 7: Koolhaas, Rem. Delirious New York: A Retroactive Manifesto for Manhattan. New York: Monacelli, 1994. Print.

Figure 8: Digital image. Vertical Village Taipei. MVRDV, n.d. Web. <http://www.mvrdv.nl/projects/THE_VERTICAL_VILLAGE_1/>.

Figure 9: Digital image. MVRDV Postaví v Jakartě Vertikální Město Peruri 88. Designmagazin, n.d. Web. <<http://www.designmagazin.cz/architektura/38089-mvrdv-postavi-v-jakarte-vertikalni-mesto-peruri-88.html>>.

Figure 10: Digital image. Shanghai Flip/City. PinkCloud.dk, n.d. Web. <<http://pinkcloud.dk/work/05/flipcity-shanghai>>.

Figure 12: Digital image. GROHE Brings Modern Lifestyle into Singapore's Marina Bay Sands Luxurious Integrated Resort

. Grohe, n.d. Web. <http://service.grohe.it/p/53_14131.html?item=973&id_cat=77>.

Figure 17: Digital image. Investing in Bamboo Plantations. Guadua Bamboo, n.d. Web. <<http://www.guaduabamboo.com/investing-in-bamboo-plantations/>>.

Figure 21: Digital image. Investing in Bamboo Plantations Bamboo Boys. The Traveling Trini, n.d. Web. <<http://thetravelingtrini.com/2012/10/23/bamboo-boys/>>.

Figure 24: Digital image. "Prefabricated Bamboo Homes." Shoo-foo. N.p., 2010. Web. 22 Dec. 2014.

Figure 26: Bo, Yuan. Bamboo Poem. Digital image. Paintings Chinese, n.d. Web. <<http://www.paintingschinese.com/chinese-bamboo-paintings/br-0607-chinese-paintings.htm>>.

Figure 28: Digital image. Kontum Indochine Café / Vo Trong Nghia Architects. Archdaily, n.d. Web. <<http://www.archdaily.com/392710/kontum-indochine-cafe-vo-trong-nghia-architects/>>.

Figure 29: Wilkie, Alice. German-Chinese House Design. 2010. Shanghai.

Figure 30: Digital image. Sendai Mediatheque. OpenBuildings, n.d. Web. <<http://openbuildings.com/buildings/sendai-mediatheque-profile-2580>>.

Figure 31: Mediateque: Blurring Architecture, Blurring Boundaries. N.p.: n.p., n.d. Web. <sites.harvard.edu/fs/docs/icb.topic502069.files/mediatheque.pdf>.

Figure 32: Swienciki, Lawrence W. Hyperboloid Model. N.p.: n.p., 2012. Print.

Figure 34: "Carlos Jarpa's Vigilante Maule Is a Timber Frame Tower Looking Out Over Chile's Vineyards." Inhabitat. N.p., n.d. Web. 27 Dec. 2014. <<http://inhabitat.com/carlos-jarpas-vigilante-maule-is-a-timber-frame-tower-looking-out-to-chiles-vineyards/carlos-jarpa-vigilante-maule-4/>>.

Figure 37: INBAR Technical Report No.16. N.p.: n.p., n.d. 76. Print.

Figure 39: INBAR Technical Report No.16. N.p.: n.p., n.d. 65. Print.